

Vertical Multistage Centrifugal in - line Pump

Dimensions and weights - PCR 150

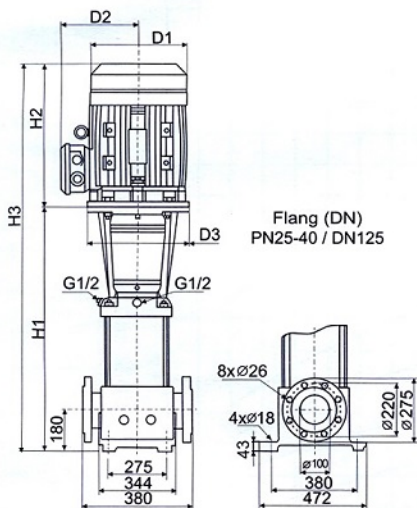

General Specification

Output size:	25 to 125 mm
Capacity:	0.7-180 m ³ /hr
Head:	275 m
Operation Temperature:	-15 to +120
Main Connection (1-[v/Hz]):	220-240 V, 50 Hz
Main Connection (3-[v/Hz]):	380-415 V, 50 Hz
Insulation Class:	F
Enclosure Class:	IP 55
Ambient Temperature:	50°C

Pump type	Motor		Pump Flanges (mm)	PCR						Net weight (kg)	
	P [kW]	rpm		Dimension(mm)			D1	D2	D3		DIN flange
				H1	H2	H3					
PCR 150-1-1	11	2900	125	834	505	1339	318	245	350	200.0	
PCR 150-1	15			834	510	1344	318	245	350	210.1	
PCR 150-2-1	22			990	580	1570	358	265	350	287.8	
PCR 150-3-2	30			1145	660	1805	420	295	400	362.3	
PCR 150-3	37			1145	660	1805	420	295	400	375.4	
PCR 150-4-1	45			1305	690	1995	470	325	450	443.4	
PCR 150-5-2	55			1486	770	2256	510	355	550	568.7	
PCR 150-6	75			1642	845	2487	580	410	550	741.0	